

Wiring Diagram

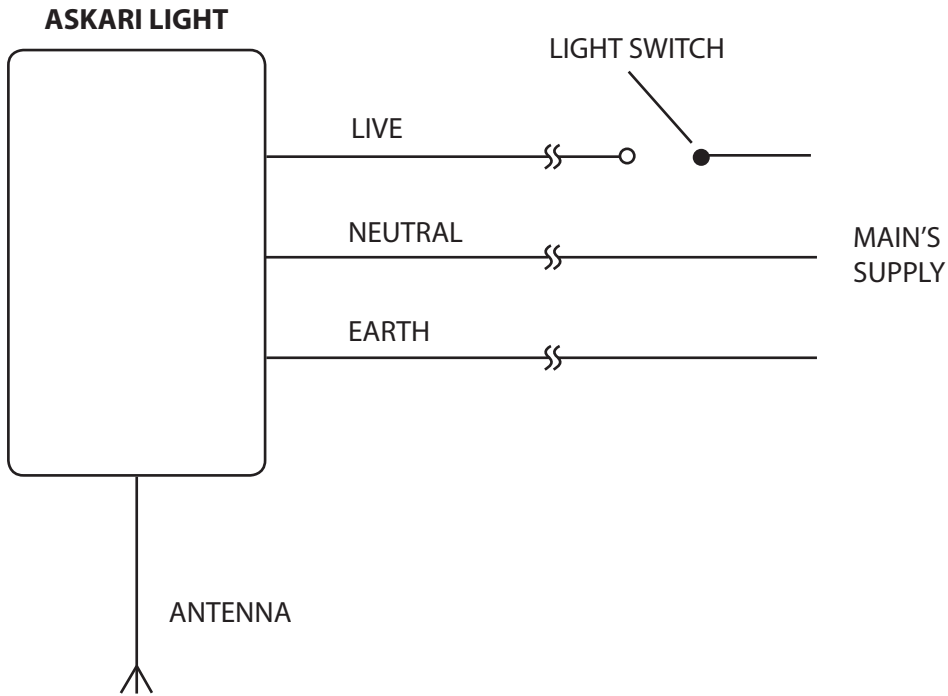

ASKARI

ASKARI

LIGHT MANUAL

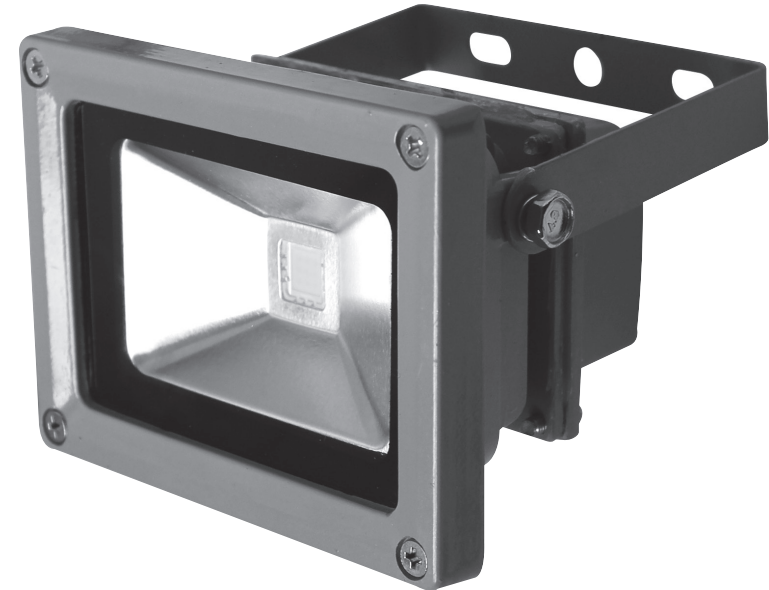

Specifications

Dimensions: 80mm x 80mm x 120mm

Weight: 525 Grams

Power: 10W max

Required Power Supply: 84 -- 265 Volts AC 50/60HZ

- The **Askari Light** can learn 3 codes . (Nano Panic, Nano Push button and a Scout intruder code)

ISO 9000-2000 Approved 



www.askaribeams.co.za

(A) General Operations

The **Askari Light** can be used to
Switch On lights when a Scout is triggered
Switch on lights from the Nano

Installation Procedure

The installation involves (B) wiring, and (C) programming.

(B) Wiring

Very Simply connect the Live Neutral and Ground leads to a switched power source.

Straighten the wire antenna, it should come out the bottom of the housing and face towards the ground.

The cable entry should also face towards the ground and have a drip loop. (Loop of cable below the entry point into the housing)

(C) Robo7 Relay Programming

To program a Scout to the Askari Light

Power up the **Askari Light** (It now has 2 minutes to receive programming code)

2. Send the Programming code from the Nano. Enter main menu (1 and 8 then right side button)
Push button 8. The Nano will display LED's 1---4
Push button 2. The Nano will display LED's 1---4
 - Button 1 = 2 minute on time
 - Button 2 = 4 minute on time
 - Button 3 = 6 minute on time
 - Button 4 = 8 minute on time

The **Askari Light** will Flash its Light to tell you it is ready to get the **Askari Scout** code now

Enter main menu(1 and 8 then right side button)
Push button 5. The Nano will display LED's of all programmed Scouts
Push button of the Scout you want the **Askari Light** to learn.
The **Askari Light** will Flash its Light to tell you it has received the code

To program a Button on the Nano to the Askari Light

Power up the **Askari Light** (It now has 2 minutes to receive programming code)

2. Send the Programming code from the Nano. Enter main menu(1 and 8 then right side button)
Push button 8. The Nano will display LED's 1---4
Push button 3. The Nano will display LED's 1---4
 - Button 1 = 2 second pulse (good for Gate Motor Application)
 - Button 2 = 3 minute pulse
 - Button 3 = Latching with the Relay accepting a PANIC code.
 - Button 4 = Latching and ignoring the PANIC code

The **Askari Light** will Flash its Light to tell you it has received the code.

Enter main menu (1 and 8 then right side button)
Push button 8. The Nano will display all LED's
Push button 4.
Push button of the Nano you want the **Askari Relay** to learn.

The **Askari Light** will Flash its Light to tell you it has received the code.

